

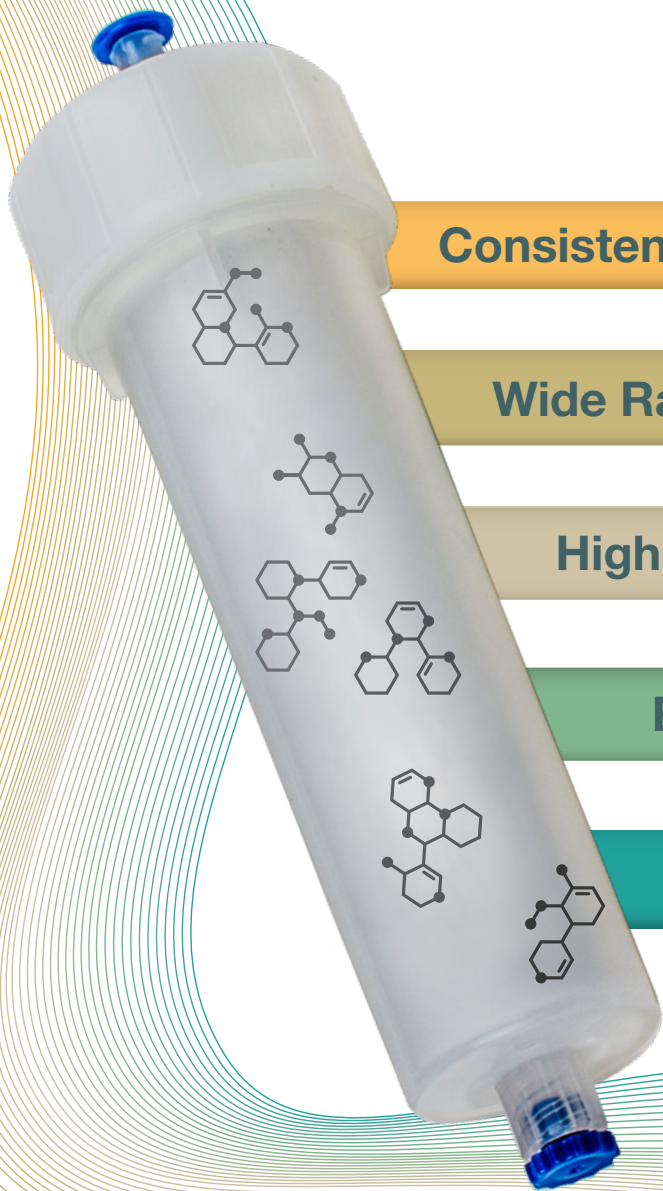

CLARICEP™ FLASH

Irregular & Spherical Silica Columns



Consistent High Performance



Wide Range of Selectivities



High Pressure Tolerance



Excellent Availability



High Quality



Switch to
CLARICEP
for
IMMEDIATE
COST SAVINGS!

Архангельск (8182)63-90-72
Астана (7172)727-132
Астрахань (8512)99-46-04
Барнаул (3852)73-04-60
Белгород (4722)40-23-64
Брянск (4832)59-03-52
Владивосток (423)249-28-31
Волгоград (844)278-03-48
Вологда (8172)26-41-59
Воронеж (473)204-51-73
Екатеринбург (343)384-55-89

Иваново (4932)77-34-06
Ижевск (3412)26-03-58
Казань (843)206-01-48
Калининград (4012)72-03-81
Калуга (4842)92-23-67
Кемерово (3842)65-04-62
Киров (8332)68-02-04
Краснодар (861)203-40-90
Красноярск (391)204-63-61
Курск (4712)77-13-04
Липецк (4742)52-20-81

Магнитогорск (3519)55-03-13
Москва (495)268-04-70
Мурманск (8152)59-64-93
Набережные Челны (8552)20-53-41
Нижний Новгород (831)429-08-12
Новокузнецк (3843)20-46-81
Новосибирск (383)227-86-73
Омск (3812)21-46-40
Орел (4862)44-53-42
Оренбург (3532)37-68-04
Пенза (8412)22-31-16

Пермь (342)205-81-47
Ростов-на-Дону (863)308-18-15
Рязань (4912)46-61-64
Самара (846)206-03-16
Санкт-Петербург (812)309-46-40
Саратов (845)249-38-78
Севастополь (8692)22-31-93
Симферополь (3652)67-13-56
Смоленск (4812)29-41-54
Сочи (862)225-72-31
Ставрополь (8652)20-65-13

Сургут (3462)77-98-35
Тверь (4822)63-31-35
Томск (3822)98-41-53
Тула (4872)74-02-29
Тюмень (3452)66-21-18
Ульяновск (8422)24-23-59
Уфа (347)229-48-12
Хабаровск (4212)92-98-04
Челябинск (351)202-03-61
Череповец (8202)49-02-64
Ярославль (4852)69-52-93

Table of Contents



CLARICEP™ Irregular Flash Media..... pp. 5-9

- Irregular CS Silica Columns pp. 6-8
- Irregular CM Silica Columns p. 9

CLARICEP Spherical Flash Media... pp. 10-18

- Spherical Silica Columns p. 11
- Spherical C18 Columns pp. 12-15
- Spherical AQ C18 Columns pp. 16-17

CLARICEP Screw-on Flash Column pp. 18-19

Ordering Information pp. 20-21

Cross Reference Guide & Phases .. pp. 22-23

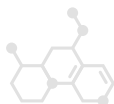

Seamlessly Upgrade from Traditional Columns to CLARICEP™ Flash!

Bonna-Agela Technologies have developed a technology that effectively deactivates the silica surface. As a result, CLARICEP Flash columns have less surface activity than ordinary silica columns and demonstrate significantly improved chromatographic performance.

Traditional Column

- High surface activity that causes instability of certain compounds
- Unwanted tailing or overly long retention of basic compounds due to secondary ionic reactions or metal chelating effects
- Poor reproducibility
- Limited selectivity range
- Pressure limited

Vs.

CLARICEP Column

- Deactivated silica surface promotes compound stability
- Excellent peak shape and performance for both acidic and basic compounds
- High quality and reproducibility
- Wide range of selectivities
- High pressure tolerance



CLARICEP™ Irregular Flash Media

CLARICEP Irregular CS Silica Columns..pp. 6-8
Ultrapure High Performance Silica

CLARICEP Irregular CM Silica Columns.....p. 9
Proprietary Silica Deactivation Process



CLARICEP™ Irregular CS Silica Columns

- Ultra pure silica packing
- Additional acid and deionized water wash
- Narrow particle size range
- Carefully controlled water content

Specification	
Surface Area:	480 m ² /g
Surface pH:	6.3-7.2
Water Content:	3.0-5.0 %
Average Particle Size:	40-60 μm
Average Pore Size:	60 Å

Improved Peak Shape and Faster Analysis

Aniline Peak Symmetry and Retention Test

Flash Conditions:

Column: Claricep Irregular Silica CS (40-60 μm, 60 Å, 40 g)
Brand I: Flash Irregular Silica (40 g)
Mobile Phase: Dichloromethane/ Methanol (99 : 1)
Flow Rate: 20 mL/min
Detector: UV @ 254 nm
Temperature: Ambient
Retention time: CLARICEP CS: 4.090 min
Brand I: 4.373 min
Sample: Aniline

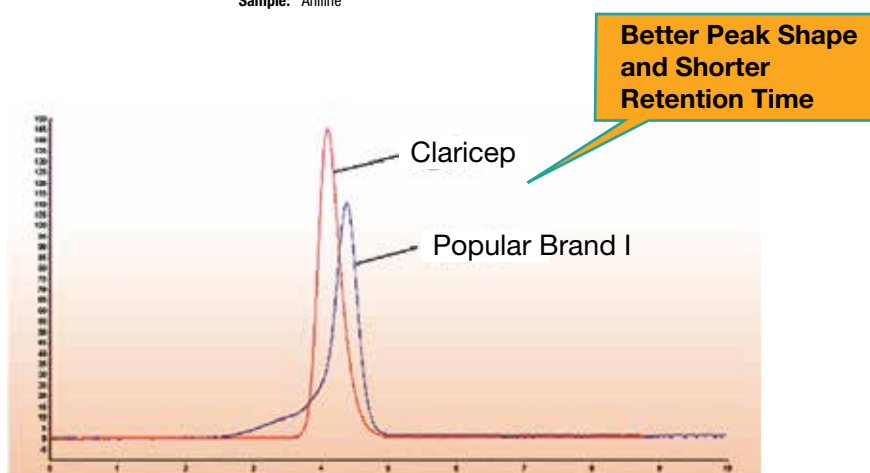

Comparative separations may not be representative of all applications.

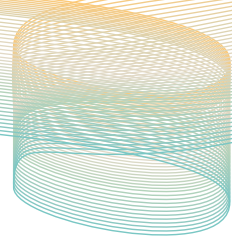

Better Retention Time & Peak Shape for Acidic Compounds!

CLARICEP™ CS 40 g

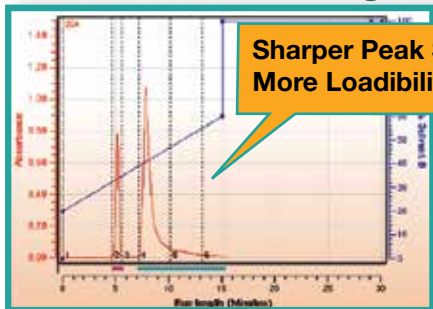

Sharper Peak Shape
More Loadability

Flash Conditions:

- Column:** Claricep Irregular Silica CS (40-60 μm , 60 \AA , 40 g)
- Brand I:** Flash Irregular Silica Column (40 g)
- Mobile Phase:** Hexane/Ethylacetate (gradient)
- Detector:** UV @ 254 nm
- Temperature:** Ambient
- Sample:** Phenyl acetone, 4-aminobenzoic acid

Popular Brand I 40 g

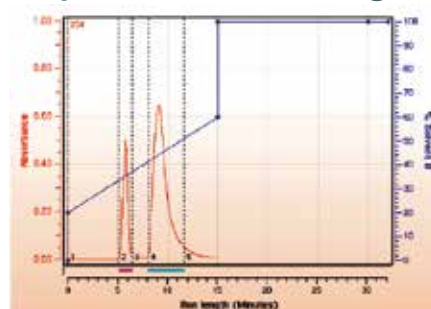

Better Peak Shape Across Different Formats

CLARICEP CS 4 g

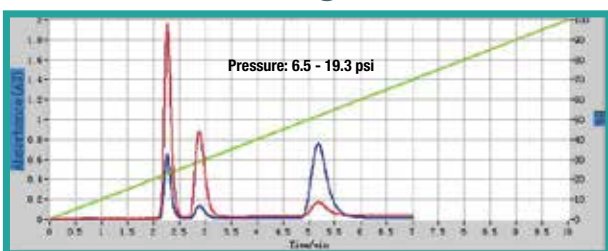

Pressure: 6.5 - 19.3 psi

Brand A Silica 4 g

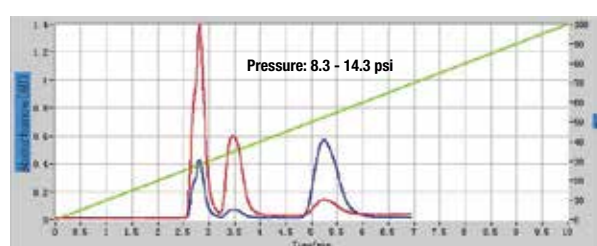

Pressure: 8.3 - 14.3 psi

Flash Conditions:

- Column:** Claricep Irregular Silica CS (40-60 μm , 60 \AA , 4g)
- Brand "A":** Irregular Silica Column (4 g)
- Mobile Phase:** A: Petroleum ether; B: Ethyl acetate
- Flow Rate:** 20 mL/min
- Detector:** UV @ 254/280 nm
- Temperature:** Ambient
- Sample:** PABA, Acetylbenzene, Methyl Paraben

Better Overall
Peak Shape

Brand A Silica 24 g

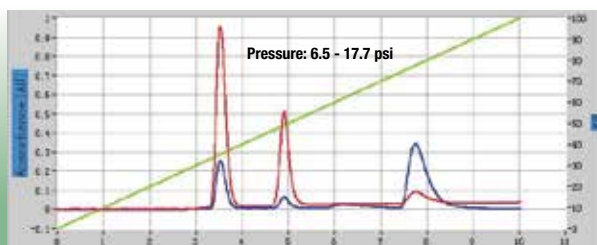

Pressure: 6.5 - 17.7 psi

CLARICEP CS Silica 20 g

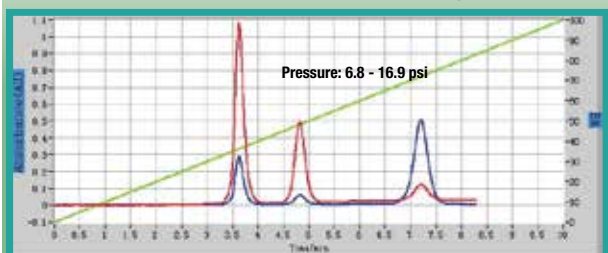

Pressure: 6.8 - 16.9 psi

Brand B Silica 25 g

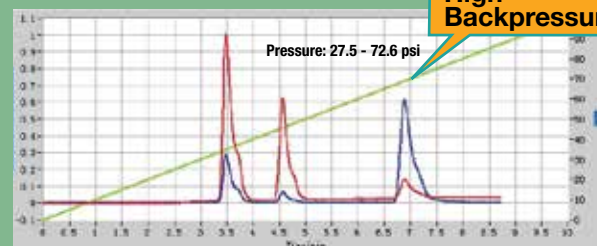

Pressure: 27.5 - 72.6 psi

High
Backpressure

Flash Conditions

- Column:** Claricep Irregular Silica CS (40-60 μm , 60 \AA , 20 g)
- Brand "A":** Flash Irregular Silica (24 g)
- Brand "B":** Flash Irregular Silica (25 g)

Mobile Phase:

- A: Petroleum ether
- B: Ethyl acetate
- Flow Rate:** 35 mL/min
- Detector:** UV @ 254/280 nm
- Sample:** PABA, Acetylbenzene, Methyl Paraben

Comparative separations may not be representative of all applications.

The Purity of Duantioxidant in Sesame Oil

HPLC Analysis

Column: Fully Porous, 5 µm, C18 Column
Dimensions: 4.6 x 150 mm
Mobile Phase: Methanol/Water (75:25)

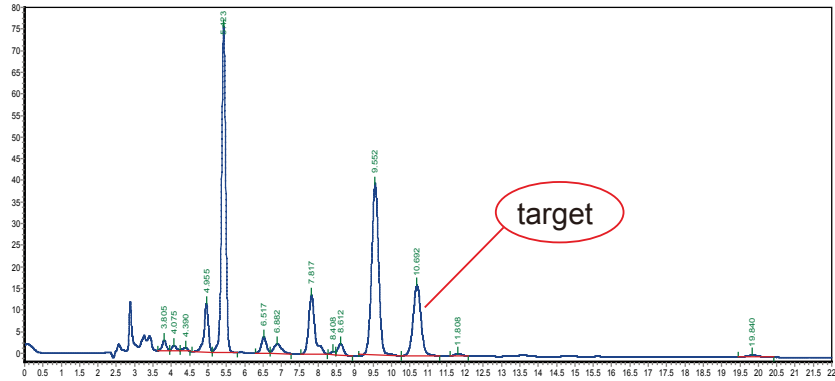

Flash Purification

Flash Conditions:
Column: Claricep™ Irregular Silica CS (40-60 µm, 60 Å, 12 g)
Part No.: CS140012-0
Mobile Phase: Acetic ether/ Petroleum ether (12:88)
Flow Rate: 18 mL/min
Injection Volume: 4 mL
Sample Concentration: 400 mg/20 mL
Instrument: CHEETAH™ MP 100

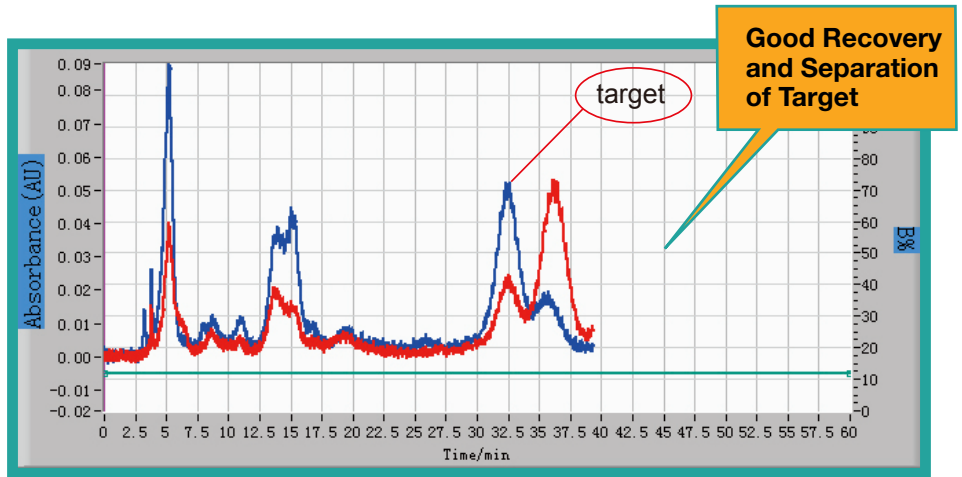

Purity Confirmation

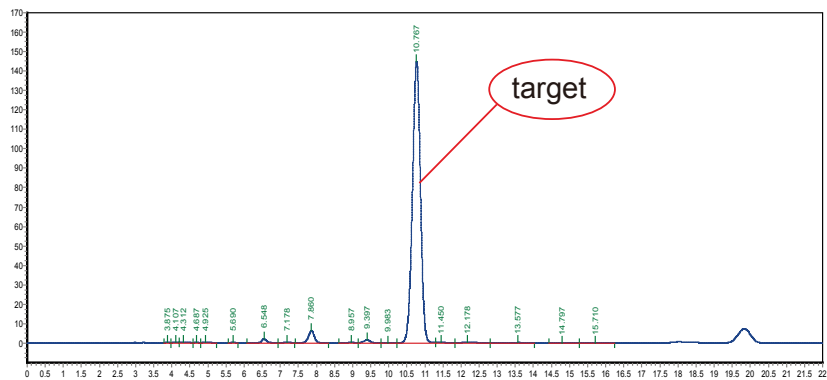

CLARICEP™ Irregular CM Silica Columns

- Significantly improved performance over regular flash columns
- Silica deactivated by proprietary process
- Alternative selectivity for complex purification requirements

Specification	
Average Particle Size:	40-60 μm
Average Pore Size:	60 \AA

Better Peak Shape With CM Silica

HPLC Test:

Unmodified and Deactivated Silica were packed into individual stainless steel columns (4.6 x 150 mm) and then evaluated on a HPLC System

HPLC Conditions:

Dimensions: 4.6 x 150 mm

Mobile Phase: Dichloromethane/Methanol (98:2)

Flow Rate: 1.8 mL/min

Injection Volume: 5 μL

Temperature: 30 $^{\circ}\text{C}$

Detector: UV @ 254 nm

Sample: Catechol 100 $\mu\text{g/mL}$

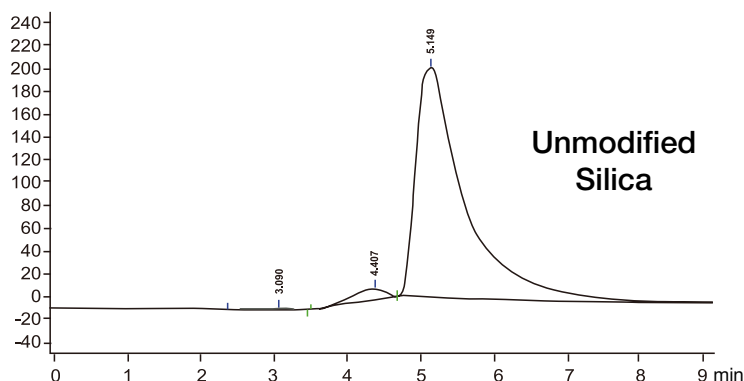

Better Peak Shape and Faster Retention Time

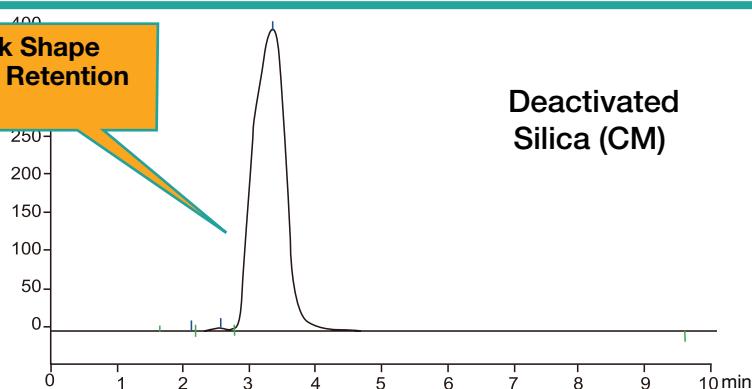

CLARICEP™ Spherical Flash Media

CLARICEP Spherical Silica Columns p. 11

CLARICEP Spherical C18 Columns pp. 12-15

CLARICEP Spherical AQ C18 Columns pp. 16-17



CLARICEP™ Spherical Silica Columns

20 µm

Specification	
Surface Area:	320 m ² /g
Water Content:	3.0 - 5.0 %
Average Pore Size:	100 Å

- Higher Resolution
- Better Purification

20-35 µm

Specification	
Surface Area:	480 m ² /g
Water Content:	3.0 - 5.0 %
Average Pore Size:	60 Å

- Lower Backpressure
- Faster Flow Rate
- Higher Loading Capacity

Specification	
Surface Area:	320 m ² /g
Water Content:	3.0 - 5.0 %
Average Pore Size:	100 Å

- Lower Backpressure
- Faster Flow Rate

Purification of a Sample with Methacrylic Acid Ester Target Compound

Sample Information:

The sample is colorless liquid, with about 60 % target compound by weight

Dissolve 0.2 mL of sample into 1.5 mL ethanol sonication

Structure:

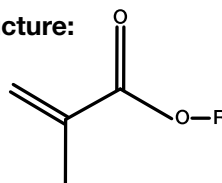

Small molecular weight with UV absorption of methacrylic acid ester
R: no UV absorption

Flash Conditions:

Column A: Claricep Spherical Silica (20-35 µm, 100 Å, 12 g, 2 columns in tandem)

Column B: Claricep Spherical Silica (20 µm, 100 Å, 12 g, 2 columns in tandem)

Mobile Phase: A: Hexane B: Ethanol

Gradient	Time/min	B %
	0	5
	20	55

Flow Rate: 12 mL/min

Detector: UV @ 254/220 nm

Sample Loading 0.2 mL

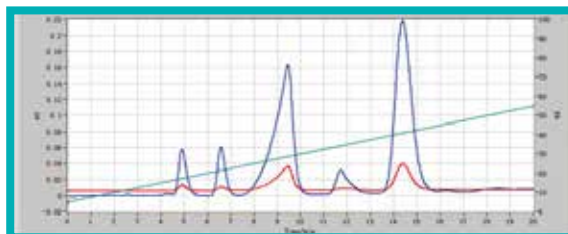

Column A: Claricep 20-35 µm

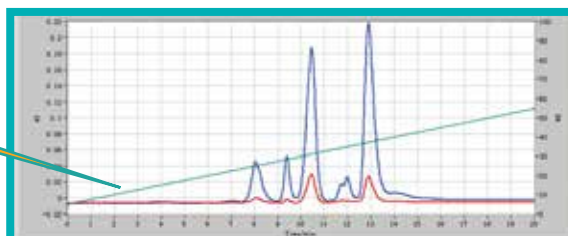

Column B: Claricep 20 µm

Claricep Flash silica 20 µm is a better choice for complex sample polarity. It provides higher resolution and better purification performance.

CLARICEP™ Spherical C18 Columns

- Significantly improved performance over regular flash columns
- Silica deactivated by proprietary process
- Alternative selectivity for complex purification requirements

Specification	
Average Particle Size:	20 μm
Average Pore Size:	100 Å
Carbon Loading:	14 %

Specification	
Average Particle Size:	20-35 μm
Average Pore Size:	60 Å
Carbon Loading:	15 %

Specification	
Average Particle Size:	20-35 μm
Average Pore Size:	100 Å
Carbon Loading:	14 %

Specification	
Average Particle Size:	40-60 μm
Average Pore Size:	100 Å
Carbon Loading:	14 %



Tetrandrine Extracted from Natural Products, Formulation

Flash Conditions:

Column A: Brand X Flash Irregular C18 (40-60 μm 100 \AA , 12 g, 3 columns in tandem)

Column B: Claricep™ Spherical C18 (20-35 μm 100 \AA , 12 g, 3 columns in tandem)

Column C: Claricep Spherical C18 (20 μm 100 \AA , 12 g, 3 columns in tandem)

Mobile Phase: A: Water
B: Methanol with 0.06% diethylamine

Gradient:

Time /min	B%
0	85
100	85

Detector: UV @ 254/282 nm

Sample: Tetrandrine

Column A:
Brand X Irregular C18,
40-60 μm

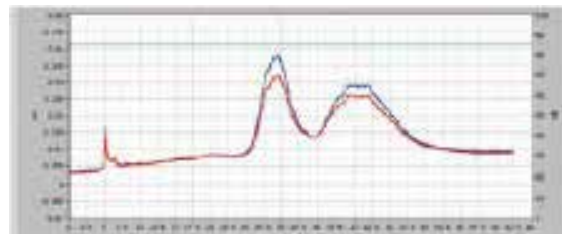

Good

Column B:
CLARICEP Spherical,
C18, 40-60 μm

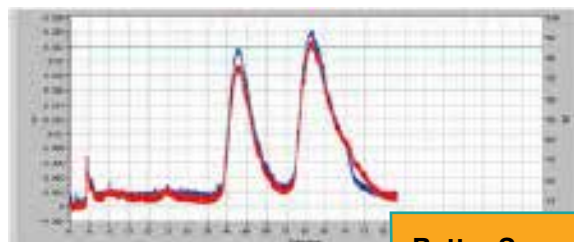

Better

Column C:
CLARICEP Spherical,
C18, 20 μm

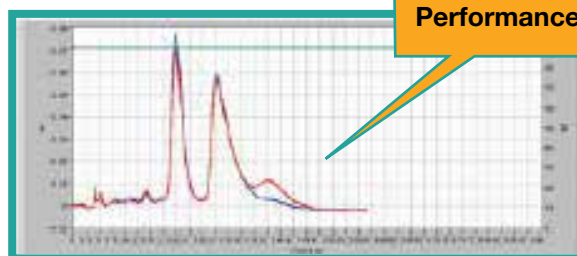

Better Separation
Performance!

Best

Comparative separations may not be representative of all applications.

Did You Know?



Flash Chromatography

also known as medium pressure chromatography is:

- A pressure driven hybrid for medium and short column chromatography optimized for rapid separation
- Popularized years ago by Clark Still of Columbia University
- An alternative to slow and inefficient gravity-fed chromatography

Ink Sample Interference / Irregular vs. Spherical

Sample Separation:

Take 50 μL of two kinds of raw ink samples separately, filter through with a 0.22 μm Nylon Filter and then load onto individual Flash columns.

Flash Conditions:

Column A: Claricep™ Irregular C18 (40-60 μm , 60 \AA , 20 g, 2 columns in tandem)

Column B: Claricep™ Spherical C18 (40-60 μm , 100 \AA , 20 g, 2 columns in tandem)

Mobile Phase: A: Water
B: Acetonitrile

Gradient:	Time /min	B%
	0	10
	60	100

Flow Rate: 26 mL/min

Detector: UV @ 254 nm (red), @ 220 nm (blue)

Instrument: CHEETAH™ MP 200

CLARICEP Irregular C18, 40-60 μm 60 \AA

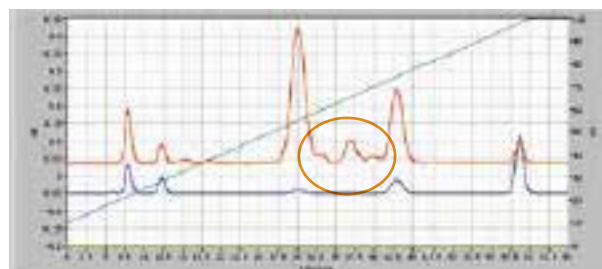

CLARICEP Spherical C18, 40-60 μm 100 \AA

Spherical Particles Produce Better Peak Shapes

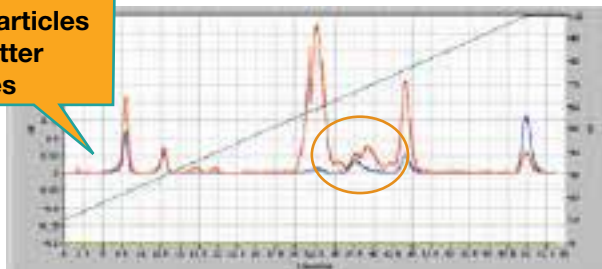

Comparative separations may not be representative of all applications.

Polypeptide Isolation

HPLC Analysis

Column: LC C18, 5 μ m, 100 \AA , 4.6 \times 150 mm
Mobile Phase: A: Water + 0.01 % TFA
B: Acetonitrile (73:27)
Flow Rate: 1 mL/min
Detector: UV @ 205 nm
Sample Injection: 1 μ L

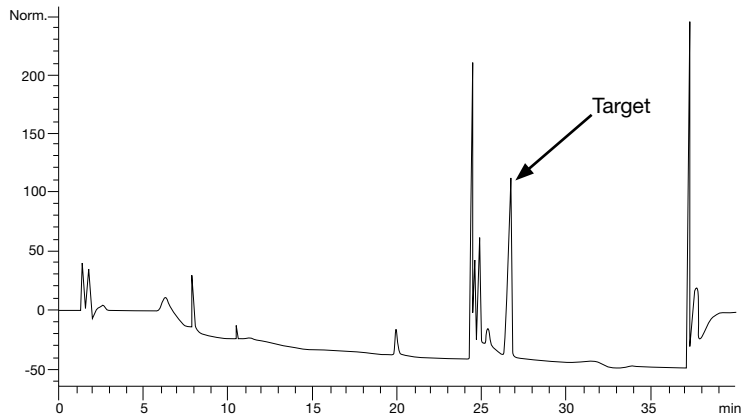

HPLC chromatogram of polypeptide

Flash Purification

Column: Claricep™ C18 (40-60 μ m, 100 \AA , 12 g)
Part No.: S0240012-0
Mobile Phase: Acetonitrile/Water
Flow Rate: 15 mL/min
Detector: UV @ 205/280 nm
Sample Injection: 2 mL

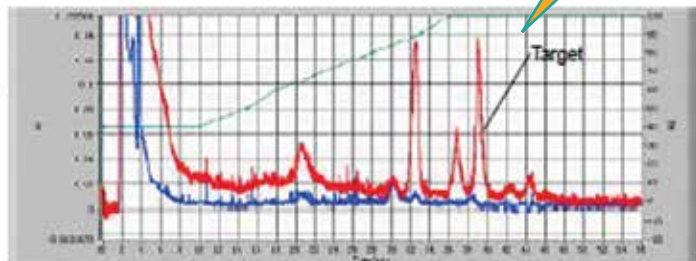

Prep chromatogram of peptide (collection time 36 - 38 min)

Excellent Separation and Resulting Sample Purity

Purity Test of the Fraction

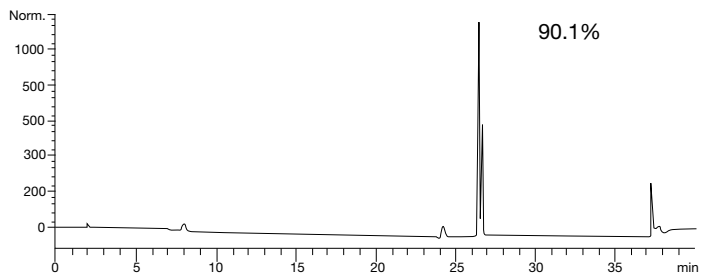

Chromatogram of the fraction

Purification of Taxol with AQ C18

Sample Separation:

The sample is an extract of Chinese yew. The target is taxol. Dissolve 1 g of sample in 20 mL methanol and filter to give a solution with a Taxol concentration of 50 mg/mL.

Concentrate the solution by evaporation rotating at 40°C, centrifuge and dissolve the supernatant into methanol, to give a final volume of 11 mL. Filter and load onto the column.

Excellent Isolated
Target Purity of ~90%

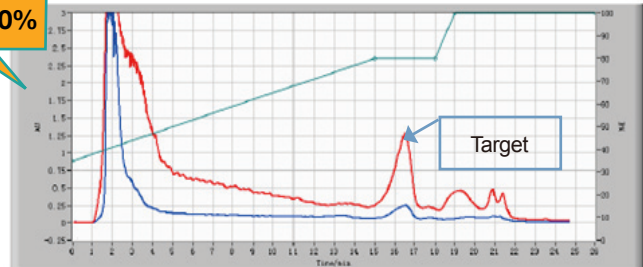

Fraction between 15-17 min

Flash Conditions:

Column: Claricep™ Spherical AQ C18 (20-35 µm, 100 Å, 120 g)

Part No.: SQ230120-0

Mobile Phase: A: Water B: Methanol

Gradient:	Time /min	B %
	0	35
	15	80
	18	80
	19	100
	25	100

Flow Rate: 83 mL/min

Detector: UV @ 230/54 nm

Sample Loading: 20 mL

Chinese Yew Tree



Conveniently Load Samples with CLARICEP™ Screw-on Flash Columns

This first series of Flash Screw-on is a new feature of Claricep columns that allows the user to load solid samples directly on the column

CLARICEP i-Series

The i-Series features a managed column head space with a secured screw-on lid. This new design allows either loading of liquid samples directly onto the column head or loading of impregnated solid sample directly into the space. Users will benefit from:

- Choice of loading method based on sample properties
- Narrow band for liquid samples because of wide loading area
- Dry-loading of solid impregnated samples minimizes band broadening
- Customized loading method upon user preference

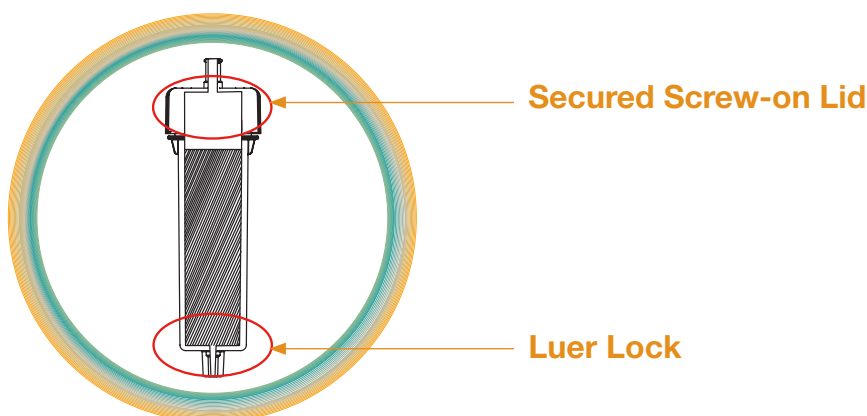

Easy to Order Screw-On Flash Columns!

For i-series: Part Number starts with "SN". As an example, to order CS140004-0 in i-series, Part Number to order is SN-CS140004-0

For s-series: Part Number starts with "S". As an example, to order CS140004-0 in s-series, Part Number to order is S-CS140004-0

For c-series: Part Number starts with "C". As an example, to order CS140004-0 in c-series, Part Number to order is C-CS140004-0

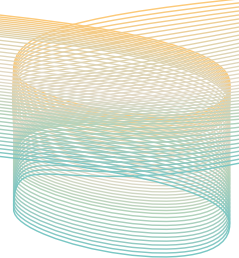

CLARICEP™ s-Series

The s-Series columns are fully packed without a head void. In addition, the Luer lock fittings for both inlet and outlet allows easy operation of tandem columns or the coupling of a loading cartridge.

- Compatible with Biotage instruments

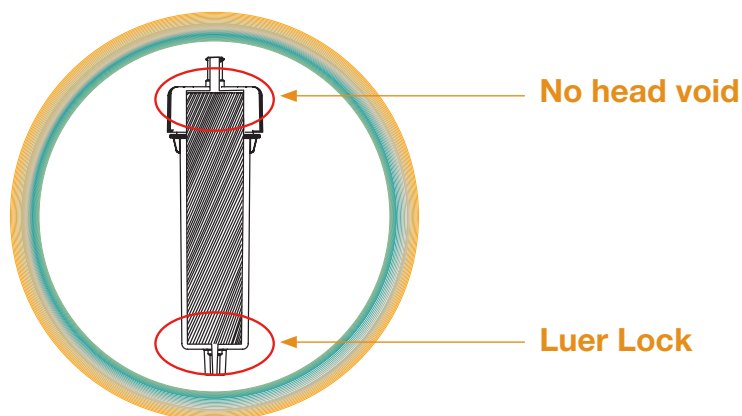

CLARICEP c-Series

The c-Series shares the same design, but the column outlet does not have a luer lock structure, this simplifies tubing connection across various flash systems.

- Compatible with instruments from the following:
 - Teledyne ISCO
 - Agela Technologies
 - Buchi
 - Grace
 - Interchim
 - Other brands

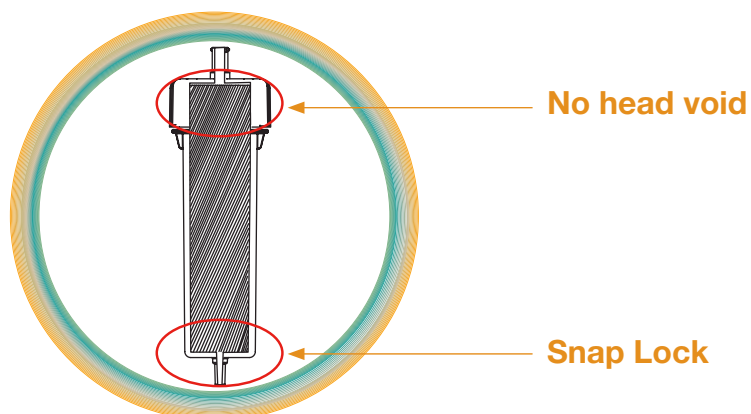



CLARICEP™

Ordering Information

Irregular Silica; Average Particle Size: 40-60 µm; Average Pore Size: 60 Å

Type	CLARICEP™	Silica Amount (g)	Quantity (pk)	Price
Silica (CS) Standard Silica	CS140004-0	4	20	
	CS140012-0	12	20	
	CS140020-0	20	20	
	CS140040-0	40	10	
	CS140080-0	80	5	
	CS140120-0	120	5	
	CS140330-0	330	1	
	CS140800-0	800	1	
	CS1401500-0	1500	1	
<i>Also available in i-series, s-series & c-series (12 g, 20 g, 40 g, 80 g, & 120 g) per request (Contact your Sales Rep)</i>				

Spherical Bonded Phase; Average Particle Size: 20-35 µm; Pore Size: 60 Å

TYPE	CLARICEP	Silica Amount (g)	Quantity (pk)	Price
Spherical Silica	SS130004-0	4	20	
	SS130012-0	12	20	
	SS130020-0	20	20	
	SS130040-0	40	10	
	SS130080-0	80	5	
	SS130120-0	120	5	
	SS130330-0	330	1	
<i>Also available in i-series, s-series & c-series (12 g, 20 g, 40 g, 80 g, & 120 g) per request (Contact your Sales Rep)</i>				

Spherical Bonded Phase; Average Particle Size: 40-60 µm; Pore Size: 100 Å

Type	CLARICEP	Silica Amount (g)	Quantity (pk)	Price
C18	SO240004-0	4	20	
	SO240012-0	12	20	
	SO240020-0	20	20	
	SO240040-0	40	10	
	SO240080-0	80	5	
	SO240120-0	120	5	
	SO240330-0	330	1	
	SO240800-0	800	1	
	SO2401500-0	1500	1	
<i>Also available in i-series, s-series & c-series (12 g, 20 g, 40 g, 80 g, & 120 g) per request (Contact your Sales Rep)</i>				

CLARICEP™

Ordering Information

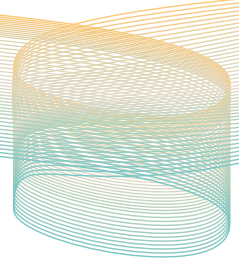

Spherical Bonded Phase; Average Particle Size: 20-35 µm; Pore Size: 100 Å

TYPE	CLARICEP™	Silica Amount (g)	Quantity (pk)	Price
C18	SO230004-0	4	20	
	SO230012-0	12	20	
	SO230020-0	20	20	
	SO230040-0	40	10	
	SO230080-0	80	5	
	SO230120-0	120	5	
	SO230330-0	330	1	
<i>Also available in i-series, s-series & c-series (12 g, 20 g, 40 g, 80 g, & 120 g) per request (Contact your Sales Rep)</i>				

Spherical Bonded Phase; Average Particle Size: 20-35 µm; Pore Size: 100 Å

TYPE	CLARICEP	Silica Amount (g)	Quantity (pk)	Price
AQ C18	SQ230004-0	4	20	
	SQ230012-0	12	20	
	SQ230020-0	20	20	
	SQ230040-0	40	10	
	SQ230080-0	80	5	
	SQ230120-0	120	5	
	SQ230330-0	330	1	
<i>Also available in i-series, s-series & c-series (12 g, 20 g, 40 g, 80 g, & 120 g) per request (Contact your Sales Rep)</i>				

guarantee

If Claricep products do not provide at least an equivalent separation as compared to other products of the same phase, mass, and size, return the product with comparative data within 45 days for a FULL REFUND.

Flash Column Cross Reference Chart

Switch to Claricep and Start Saving Money!

Biotage®		Teledyne ISCO	CLARICEP™			
Part No.	Part No.	Part No.	Product Name	Phase	Mass (g)	Unit
440-0500-DZ-20	692203304	CS140004-0	CLARICEP Flash Silica (CS) column	Silica	4	20/pk
440-1000-EZ-20	692203312	CS140012-0	CLARICEP Flash Silica (CS) column	Silica	12	20/pk
440-3000-FZ-20	692203324	CS140020-0	CLARICEP Flash Silica (CS) column	Silica	20	20/pk
440-4500-SZ-20	692203340	CS140040-0	CLARICEP Flash Silica (CS) column	Silica	40	10/pk
440-8000-JZ-20	692203380	CS140080-0	CLARICEP Flash Silica (CS) column	Silica	80	5/pk
440-120G-UZ-20	692203320	CS140120-0	CLARICEP Flash Silica (CS) column	Silica	120	5/pk
	692203330	CS140330-0	CLARICEP Flash Silica (CS) column	Silica	330	1/pk
	692203275	CS140800-0	CLARICEP Flash Silica (CS) column	Silica	800	1/pk
	692203277	CS1401500-0	CLARICEP Flash Silica (CS) column	Silica	1500	1/pk
	692203328	SO230004-0	CLARICEP Flash Spherical C18 column	C18	4	20/pk
FSUL-0401-0012	692203334	SO230012-0	CLARICEP Flash Spherical C18 column	C18	12	20/pk
FSUL-0401-0030	692203335	SO230020-0	CLARICEP Flash Spherical C18 column	C18	20	20/pk
FSUL-0401-0060	692203336	SO230040-0	CLARICEP Flash Spherical C18 column	C18	40	10/pk
	692203337	SO230080-0	CLARICEP Flash Spherical C18 column	C18	80	5/pk
FSUL-0401-0120	692203338	SO230120-0	CLARICEP Flash Spherical C18 column	C18	120	5/pk
FSUL-0401-0400	692203339	SO230330-0	CLARICEP Flash Spherical C18 column	C18	330	1/pk
	692203410	SO240004-0	CLARICEP Flash Spherical C18 column	C18	4	20/pk
	692203411	SO240012-0	CLARICEP Flash Spherical C18 column	C18	12	20/pk
	692203412	SO240020-0	CLARICEP Flash Spherical C18 column	C18	20	20/pk
	692203413	SO240040-0	CLARICEP Flash Spherical C18 column	C18	40	10/pk
	692203416	SO240080-0	CLARICEP Flash Spherical C18 column	C18	80	5/pk
	692203414	SO240120-0	CLARICEP Flash Spherical C18 column	C18	120	5/pk
	69-2203-415	SO240330-0	CLARICEP Flash Spherical C18 column	C18	330	1/pk
		SO240800-0	CLARICEP Flash Spherical C18 column	C18	800	1/pk
		SO2401500-0	CLARICEP Flash Spherical C18 column	C18	1500	1/pk
	69-2203-558	SQ230004-0	CLARICEP Flash Spherical AQ C18 column	AQ C18	4	20/pk
	69-2203-559	SQ230012-0	CLARICEP Flash Spherical AQ C18 column	AQ C18	12	20/pk
	69-2203-560	SQ230020-0	CLARICEP Flash Spherical AQ C18 column	AQ C18	20	20/pk
	69-2203-561	SQ230040-0	CLARICEP Flash Spherical AQ C18 column	AQ C18	40	10/pk
	69-2203-562	SQ230080-0	CLARICEP Flash Spherical AQ C18 column	AQ C18	80	5/pk
	69-2203-563	SQ230120-0	CLARICEP Flash Spherical AQ C18 column	AQ C18	120	5/pk
	69-2203-564	SQ230330-0	CLARICEP Flash Spherical AQ C18 column	AQ C18	330	1/pk
	692203344	SS130004-0	CLARICEP Flash Spherical Silica column	Silica	4	20/pk
FSUL-0442-0010	692203345	SS130012-0	CLARICEP Flash Spherical Silica column	Silica	12	20/pk
FSUL-0442-0025	692203346	SS130020-0	CLARICEP Flash Spherical Silica column	Silica	20	20/pk
FSUL-0442-0050	692203347	SS130040-0	CLARICEP Flash Spherical Silica column	Silica	40	10/pk
FSUL-0442-0100	692203348	SS130080-0	CLARICEP Flash Spherical Silica column	Silica	80	5/pk
	692203349	SS130120-0	CLARICEP Flash Spherical Silica column	Silica	120	5/pk
FSUL-0442-0340	692203369	SS130330-0	CLARICEP Flash Spherical Silica column	Silica	330	1/pk

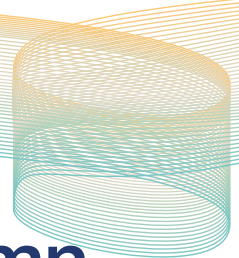

Additional CLARICEP™ Flash Column Phases, Formats, and Sizes Available

Particle Size	Particle Shape	Pore Size	Phase			
40 - 60 µm	Irregular Silica	60 Å	Standard Silica (CS)			
			Deactivated Silica (CM)			
			C18			
			AQ C18			
			HILIC			
			NH2			
			C8			
			SAX			
			SCX			
	Irregular Alumina Al ₂ O ₃	60 Å	C18			
			AQ C18			
			C18			
20 µm	Spherical Silica	100 Å	Standard Silica (CS)			
			Alumina Neutral			
20-35 µm	Spherical Silica	60 Å	Alumina Basic			
			Alumina Acidic			
			Spherical Silica			
		100 Å	Deactivated Silica (CM)			
			Spherical C18			
			Spherical C8			
			Spherical AQ C18			
			Spherical HILIC			
			Spherical HLP			
			Spherical NH2			
			Spherical Phenyl			
			Spherical CN			
			Spherical Diol			
			50 µm	60 Å	120 Å	Spherical Silica
						Spherical C18
Spherical Silica						
50 µm	120 Å	120 Å	Spherical C18			
			Spherical C18			

Архангельск (8182)63-90-72
 Астана (7172)727-132
 Астрахань (8512)99-46-04
 Барнаул (3852)73-04-60
 Белгород (4722)40-23-64
 Брянск (4832)59-03-52
 Владивосток (423)249-28-31
 Волгоград (844)278-03-48
 Вологда (8172)26-41-59
 Воронеж (473)204-51-73
 Екатеринбург (343)384-55-89

Иваново (4932)77-34-06
 Ижевск (3412)26-03-58
 Казань (843)206-01-48
 Калининград (4012)72-03-81
 Калуга (4842)92-23-67
 Кемерово (3842)65-04-62
 Киров (8332)68-02-04
 Краснодар (861)203-40-90
 Красноярск (391)204-63-61
 Курск (4712)77-13-04
 Липецк (4742)52-20-81

Магнитогорск (3519)55-03-13
 Москва (495)268-04-70
 Мурманск (8152)59-64-93
 Набережные Челны (8552)20-53-41
 Нижний Новгород (831)429-08-12
 Новокузнецк (3843)20-46-81
 Новосибирск (383)227-86-73
 Омск (3812)21-46-40
 Орел (4862)44-53-42
 Оренбург (3532)37-68-04
 Пенза (8412)22-31-16

Пермь (342)205-81-47
 Ростов-на-Дону (863)308-18-15
 Рязань (4912)46-61-64
 Самара (846)206-03-16
 Санкт-Петербург (812)309-46-40
 Саратов (845)249-38-78
 Севастополь (8692)22-31-93
 Симферополь (3652)67-13-56
 Смоленск (4812)29-41-54
 Сочи (862)225-72-31
 Ставрополь (8652)20-65-13

Сургут (3462)77-98-35
 Тверь (4822)63-31-35
 Томск (3822)98-41-53
 Тула (4872)74-02-29
 Тюмень (3452)66-21-18
 Ульяновск (8422)24-23-59
 Уфа (347)229-48-12
 Хабаровск (4212)92-98-04
 Челябинск (351)202-03-61
 Череповец (8202)49-02-64
 Ярославль (4852)69-52-93